

# SL30SGL

## Sideload Lock



## Table on Contents:

<b>1. Description</b>	<b>2</b>
<b>2. Product Unboxed</b>	<b>3</b>
<b>3. Dimensions</b>	<b>4/5</b>
3.1 Lock	4
3.2 Strike Plate	4
3.3 Fitting Tab	4
3.4 Housing	5
3.5 Dress Plate	5
<b>4. Pre - Installation Assessment</b>	<b>6/7</b>
4.1 Mechanical	6
4.2 Electrical	7
<b>5. Installation</b>	<b>8/11</b>
5.1 Mortice Installation	8/9
5.2 Surface Installation	9/11
<b>6. Wiring</b>	<b>12/13</b>
6.1 Fail Safe Connection	12
6.2 Fail Secure Connection	13
6.3 Jumper Position	13
<b>7. Operation</b>	<b>14</b>
7.1 Fail Safe Operation	14
7.2 Fail Secure Operation	14
<b>8. Specifications</b>	<b>15</b>
<b>9. Maintenance</b>	<b>16</b>
<b>10. Warranty</b>	<b>16</b>

# 1. Description

The SL30SGL is a motor driven low voltage electric lock designed to secure commercial and residential doors. The lock has been designed to address the two biggest issues in concealed electric locking today;

**1. The ability to 'pull' a door into alignment even if the door has not closed in a central position.**

**2. The ability to release when requested even if there is excessive load on the door.**

The bolt pin of the SL30SGL operates on a cam action which enables the bolt pin to pull a door into place. In practice, as the door closes it may come to rest in a position that is not fully closed, especially if closing against a door seal of some type. The SL30SGL senses when the door is within 8mm (5/16 inch) of being fully closed and activates the bolt pin. The bolt pin then rotates out and pulls the door from its resting position to the closed and sealed position.

With the door secured and locked the SL30SGL can be given an unlock signal and it will instantly unlock. If the door is loaded (pre-load) when the unlock signal is given the SL30SGL will still unlock, even with loads in excess of 500kg on the door. Critically, the ability of the SL30SGL to instantly release with excessive pre-load on the door even occurs in the event of a power failure, providing the lock is configured as fail safe.



Additional features of the SL30SGL are;

- Multi-voltage input (12 - 24VDC)
- Very low current consumption
- Door position and bolt position monitors
- High physical strength
- Fail-safe / Fail-secure on-site conversion with the re-positioning of a single switch

## 2. Product Unboxed

Along with the SL30 SGL lock and matching strike, there are also 4x 10G self-tapping screws supplied.

The 7 way wire loom supplied is used to ease installation as the wiring can be done without the lock being installed until the very end.

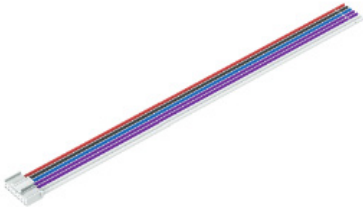
1x Lock	1x Strike Plate
	
4x 10G self-tapping screws	1x 300mm 7-way wire loom
	

### 3. Dimensions

#### 3.1 Lock

The dimensions shown are approximate and subject to change without prior notice.

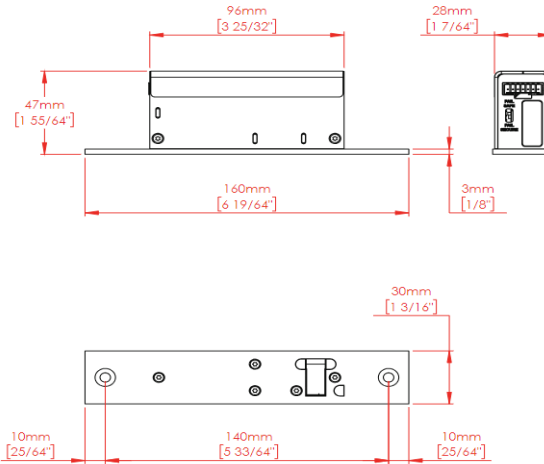

#### 3.2 Strike Plate

The dimensions shown are approximate and subject to change without prior notice.

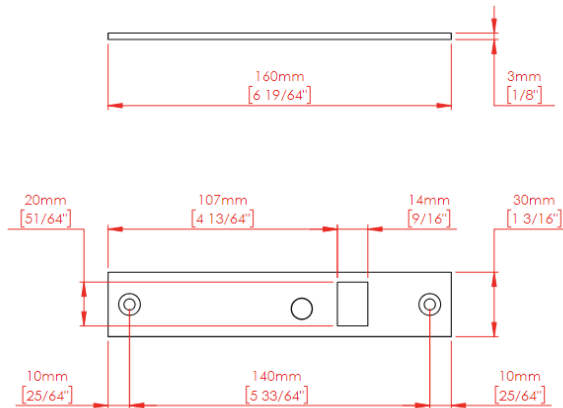

#### 3.3 Fitting Tab

Available seperately - The dimensions shown are approximate and subject to change without prior notice.

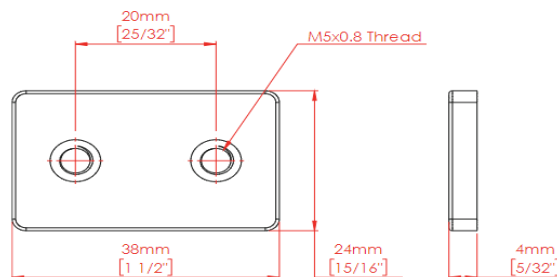

### 3.4 Housing

Available separately- The dimensions shown are approximate and subject to change without prior notice.

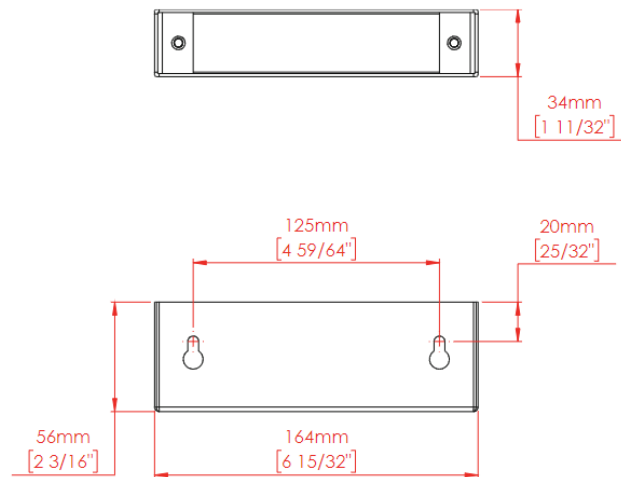

### 3.5. Dress Plate

Available separately - The dimensions shown are approximate and subject to change without prior notice.

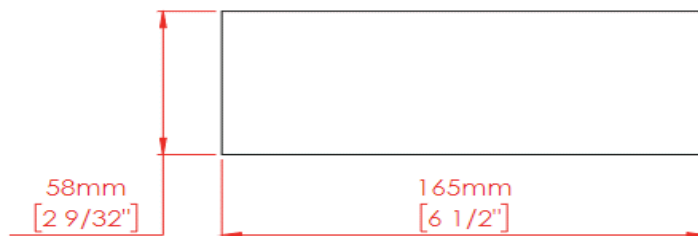

## 4. Pre-Installation Assessment

### 4.1 Mechanical

The SL30SGL is designed for mortise installations as this offers a discrete solution as the lock and strike plate can be embedded into the door and frame. In some instances however mortise installation is not possible so by utilising the housing, surface installation of the SL30SGL is possible. Whichever installation method is chosen it is important that the lock and strike plate are aligned correctly. The strike plate has an opening to accept the bolt pin and centring this opening with the bolt pin will ensure correct operation.

**The SL30SGL can be installed vertically or horizontally but is not designed to be mounted in a floor cavity firing upwards or in a wet environment.**

When installing the SL30SGL vertically, take note of which way the door is closing from. If the door is approaching from the left the bolt pin is at the top, if the door is approaching from the right then the bolt pin is at the bottom, as indicated below:

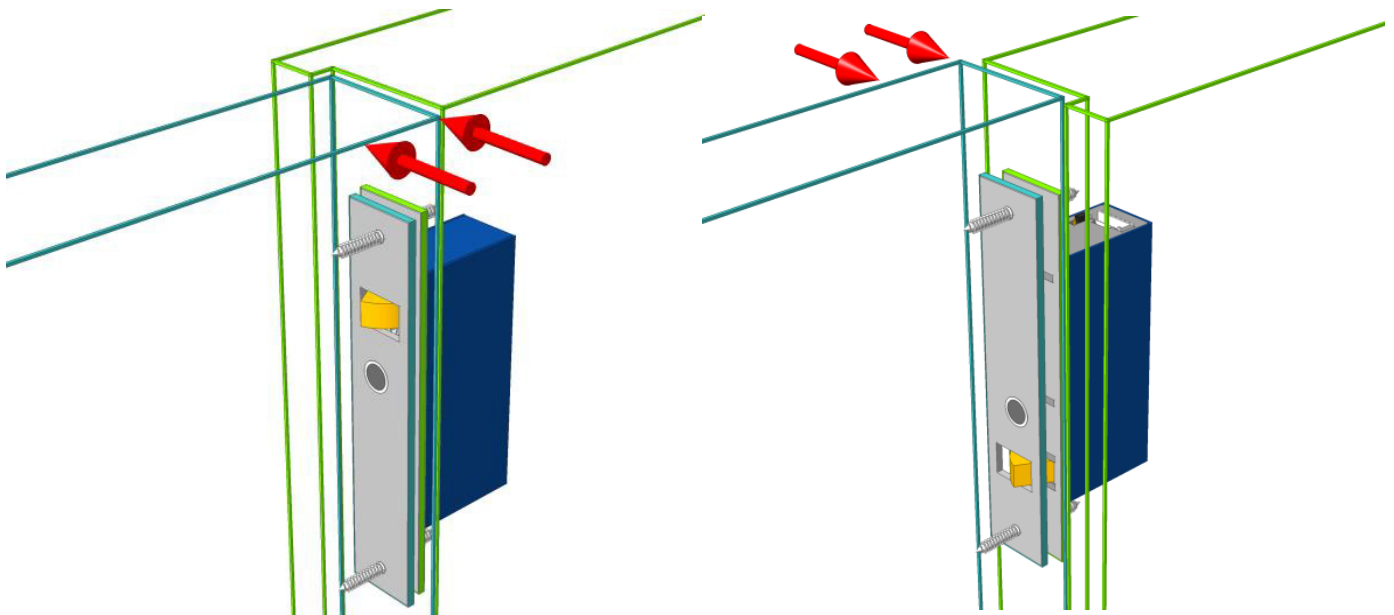

Door closing from the left, the lock is installed with the bolt pin at the top.

Door closing from the right, the lock is installed with the bolt pin at the bottom.

## 4.2 Electrical

The first consideration is to establish where to run the wires and decide on what feedback is required from the lock. There are a total of seven available connections; three are compulsory power connections whilst the remaining four provide optional door and bolt position feedback. These optional connections can be integrated into access control or alarm systems to provide full monitoring.

The correct gauge of wire needs to be chosen as voltage drop across the power wires (+ and -) can limit the locks operation. For all the remaining connections, a lower gauge wire can be used as these are only signal wires. The following chart shows the maximum distance that the power supply can be away from the lock, assuming the power supplies output 12VDC or 24VDC:

AWG	Area (mm <sup>2</sup> )	Maximum Distance (m)	
		12VDC	24VDC
24	0.20	7	20
22	0.33	11	32
20	0.52	17	51
18	0.82	27	82
16	1.31	43	130
14	2.08	69	206



## 5. Installation

Two installation examples are detailed on the following pages; mortise and surface, however any combination of the two can be achieved. Whichever installation method is chosen it is **vital to ensure that the lock face plate and the strike plate align correctly and the gap between the lock face plate and strike plate does not exceed 8mm when the door is closed.**

### 5.1 Mortise Installation

A typical mortise installation is described with the lock fitted into the door frame and the strike plate secured into the door. It is possible to install the lock into the door and the strike plate into the frame however with this method running wiring to the lock requires additional work.

#### 5.1.1 Cutting the mortices

Referring to the dimension drawings in Section 3; mortices are cut into the door and door frame suitable to fit the strike plate and lock. Wooden doors and frames require full mortices where metal doors and frames, being hollow, often only require a single rectangle cut-out to accommodate the lock face plate or strike plate. For these installations fitting tabs can be used to secure the lock and strike plate in place.

The mortice behind the lock body needs to have enough space to accommodate the wiring.

#### 5.1.2 Wiring the lock

Wires are run from the power supply to the lock. A hole needs to be drilled in the back of the mortice to bring the wires out and a connection can be made to the supplied wire loom which in turn plugs into the lock. The jumper needs to be positioned for fail safe / fail secure configuration as per the instructions on the lock cover.

The Red, Black and Blue wires are essential connections whilst the Violet and White are optional. Detailed wiring instructions are found in Section 6.

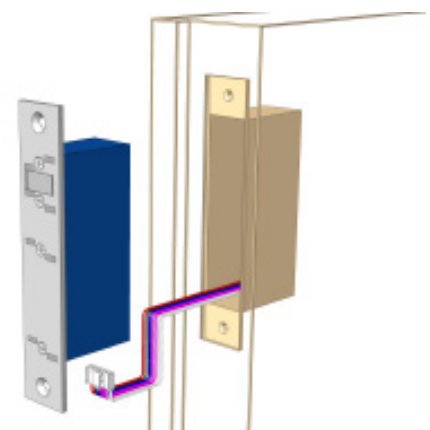
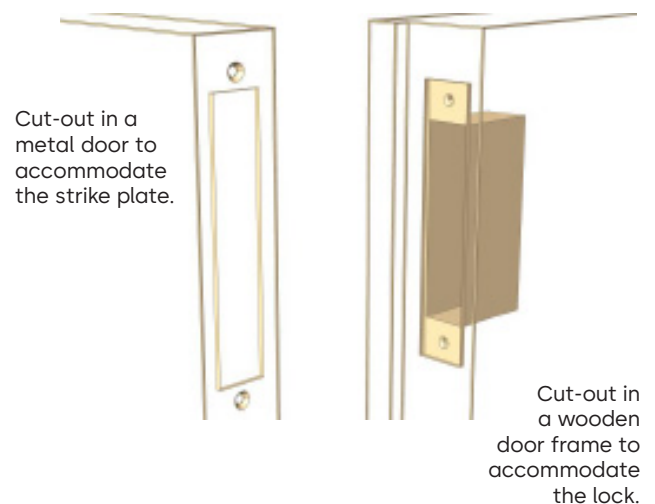

### 5.1.3 Fitting the lock and strike plate

The lock is slid back into the mortice, making sure that the wiring integrity is maintained and secure in place with the supplied 10G self-tapping screws.

Before the strike plate is installed the fitting tabs are secured in behind the cut-out using the supplied M5 machine screws. The strike plate is then placed into the cut out and the remaining M5 screws are used to secure it.

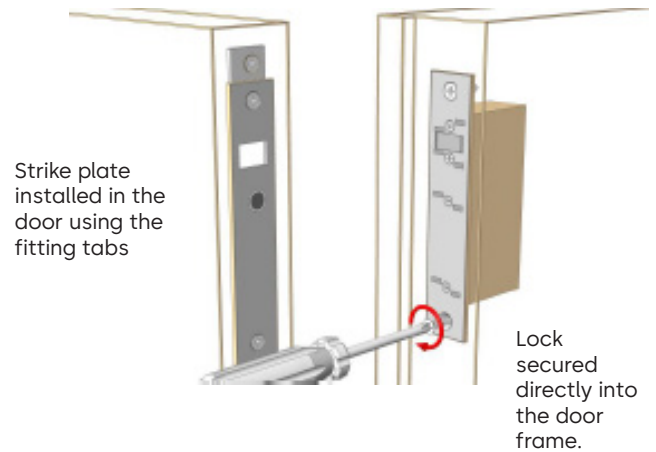

### 5.1.4 Checking the operation

With the lock and strike installed and wiring complete the door is closed to check the alignment and operation. The key area for alignment is the bolt pin; the pin is designed to touch the leading edge of the strike plate hole to pull the door in, but it cannot be allowed to touch the sides of the hole as this will limit its unlocking ability. If it rubs or touches the side of the strike plate hole, either the lock or strike plate needs to be re-positioned.

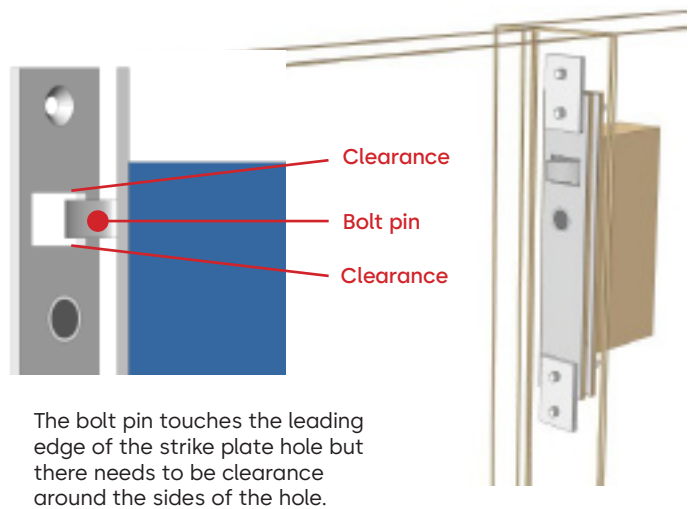

## 5.2 Surface Installation

By using housing, the lock and or strike plate can be surface mounted to the door or door frame eliminating the need for cutting mortises. Housings are available with adhesive tape supplied for easy application to glass doors in addition to having screw hole mounting points for wood and metal doors.

### 5.2.1 Securing the lock housing to wood

Before fitting the housing, determine exactly where the wiring will enter the housing and drill one or two 8mm holes through the housing wall. Ensure the holes are on the housing face that goes against the wooden frame. Push the supplied grommet(s) into the drilled hole(s). The two 10G Hex head self tapping screws supplied with the housing can then be screwed into the wood but not tightened. The two keyhole shaped cut outs in the housing fit over these screw heads which are tightened with a ring spanner once the housing is in place.

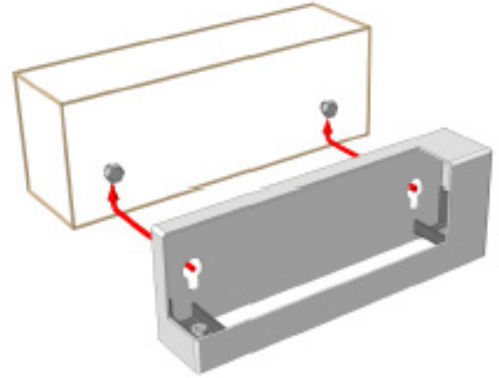

### 5.2.2 Wiring the lock

Wires are run from the power supply to the lock through the drilled hole(s) in the housing. A connection can be made to the supplied wire loom which in turn plugs into the lock. The jumper needs to be positioned for fail safe / fail secure configuration as per the instructions on the lock cover.

The Red, Black and Blue wires are essential connections whilst the Violet and White are optional. Detailed wiring instructions can be found in Section 6.

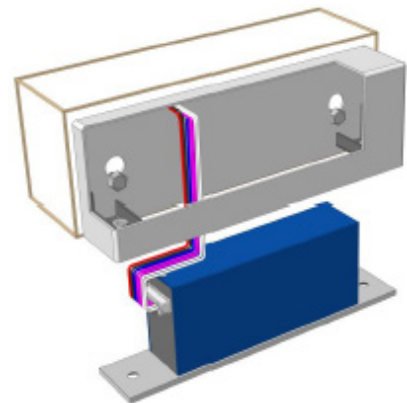

### 5.2.3 Fitting the lock into the housing

Once wired, the lock is slid into the housing and secured in place with the supplied M5 machine screws. Make sure that the wiring integrity is maintained as the lock is screwed in place.

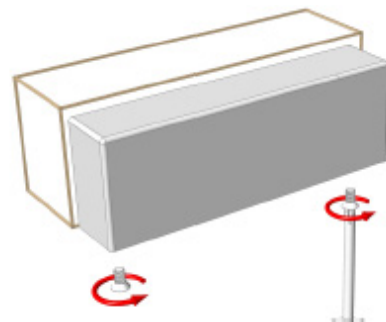

## 5.2.4 Fitting the strike plate housing to glass

For simple application to glass the housing is supplied with self-adhesive tape. With the backing removed the housing can be applied directly to the glass. A flat stainless steel dress plate is fitted on the opposite side of the glass to give a clean finish. The protective coating on the dress plate can be removed once it is in place.

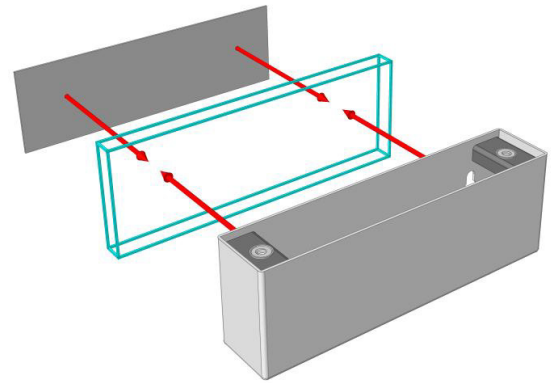

## 5.2.5 Fitting the strike plate into the housing

The strike plate is placed into the housing and secured in place with the supplied M5 machine screws.

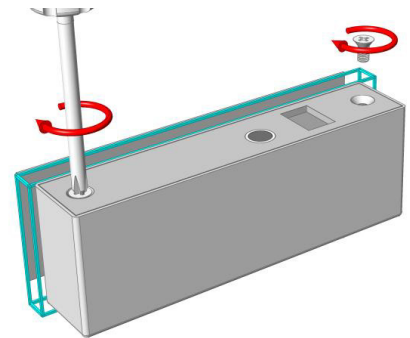

## 5.2.6 Checking the operation

With the lock and strike installed and wiring complete the door is closed to check the alignment and operation. The key area for alignment is the bolt pin; the pin is designed to touch the leading edge of the strike plate hole to pull the door in, but it cannot be allowed to touch the sides of the hole as this will limit its unlocking ability. If it rubs or touches the side of the strike plate hole, either the lock or strike plate needs to be re-positioned.

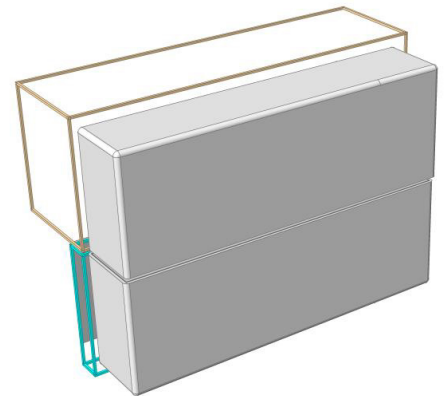

## 6. Wiring

The SL30SGL is supplied with a 7-way wire loom that plugs directly into the lock. The wires are colour coded with three being essential connections and four optional. Control of the lock is achieved by using the three power wires, whilst door and bolt position monitoring are available when desired. Connect the SL30SGL as per the chart:

RED BLACK BLUE	POS NEG CTRL	Positive connection to DC power supply (12-24V) Negative connection to DC power supply (12-24V) Switched positive control input	Power
VIOLET VIOLET	NO COM	Contacts closed when bolt pins are extended, and contacts open when bolt pins are retracted	Bolt Position Switch
WHITE WHITE	NO COM	Contacts closed when door is aligned, and contacts open when door is open	Door Position Switch

### 6.1 Fail Safe Connection

When wiring the SL30SGL, the positive voltage is connected to RED, negative is connected to BLACK and a switched positive voltage wire connected to BLUE. In Fail Safe configuration applying voltage to the SL30SGL signals it to lock. The lock signal in Fail Safe configuration is active high.

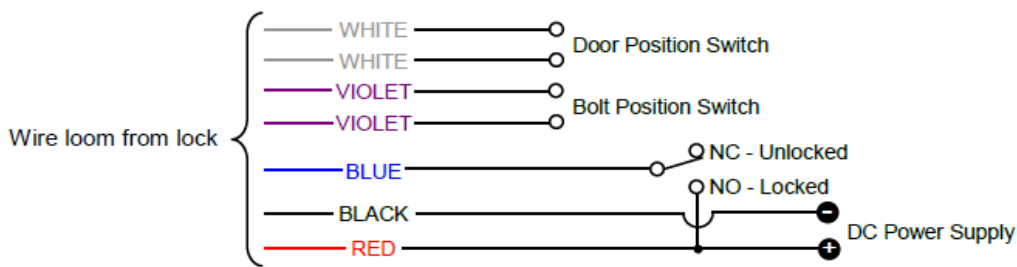

## 6.2 Fail Secure Connection

When wiring the SL30SGL, the positive voltage is connected to RED, negative is connected to BLACK and a switched positive voltage wire connected to BLUE. In Fail Secure configuration applying voltage to the SL30SGL signals it to unlock. The lock signal in Fail Secure configuration is active low.

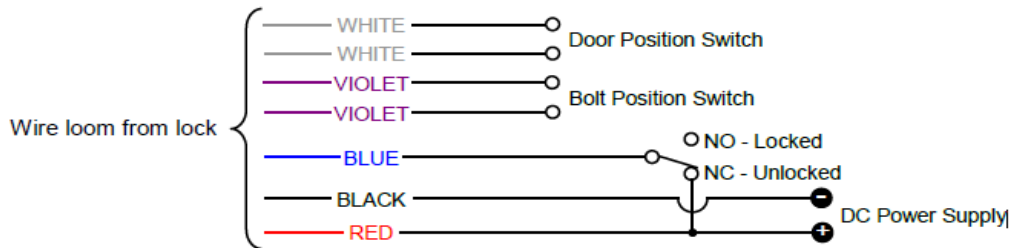

## 6.3 Jumper Position

The fail mode of the SL30SGL is factory set as Fail Safe, i.e. in the event of a power cut the SL30SGL will unlock. Before the lock is installed this can be changed to Fail Secure by repositioning the jumper located next to the 7-way plug on the end of the lock. Select the desired jumper location as indicated:

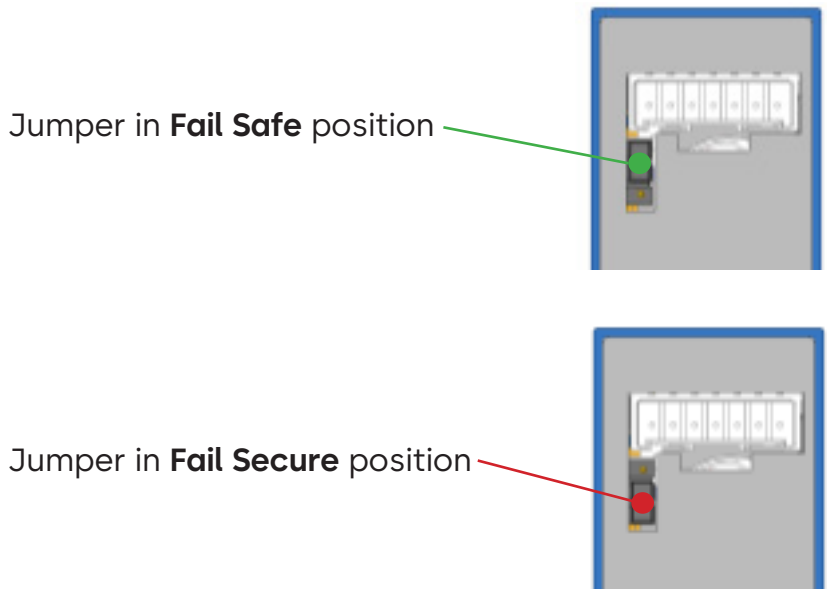

Fail Safe	=	Fail Unlocked	=	Power To Lock	=	PTL
Fail Secure	=	Fail Locked	=	Power to Open	=	PTO

# 7. Operation

## 7.1 Fail Safe Operation

Assume the lock is installed and wired, the door is open and there is voltage applied to the BLUE wire. As the door closes the SL30SGL senses the door approaching and activates the appropriate bolt pin to pull the door into centre alignment. Once the first bolt pin has fully extended, the second bolt pin activates and drives to its full extension. If the door closes to a centre aligned position quickly then both bolt pins activate at the same time rather than one leading the other. The Bolt Position and Door Position monitors will have changed state as the door is moved into place and secured.

To unlock the door, voltage is removed from the BLUE wire. The SL30SGL will immediately release and will do so even when significant load is being applied to the door. With the door now open the Bolt Position and Door Position monitors change state again. The SL30SGL will remain unlocked as long as the door is open but will instantly re-lock when voltage is applied to the BLUE wire and the door is closed.

In the event of a power failure, voltage is removed from the BLUE wire and the SL30SGL unlocks.

## 7.1 Fail Secure Operation

Assume the lock is installed and wired, the door is open and voltage is removed from the BLUE wire. As the door closes the SL30SGL senses the door approaching and activates the appropriate bolt pin to pull the door into centre alignment. Once the first bolt pin has fully extended, the second bolt pin activates and drives to its full extension. If the door closes to a centre aligned position quickly then both bolt pins activate at the same time rather than one leading the other. The Bolt Position and Door Position monitors will have changed state as the door is moved into place and secured.

To unlock the door, voltage is applied to the BLUE wire. The SL30SGL will immediately release and will do so even when significant load is being applied to the door. With the door now open the Bolt Position and Door Position monitors change state again. The SL30SGL will remain unlocked as long as the door is open but will instantly re-lock when voltage is removed from the BLUE wire and the door is closed.

In the event of a power failure, voltage is removed from the BLUE wire and the SL30SGL locks if the door is closed.

## 8. Specifications

<b>Materials</b>	
Bolt Pin	SS17-4PH, 10mm Thick, 13mm extension Extension
Strike Plate	SS304, 3mm Thick
Lock Face Plate	SS304, 3mm Thick
<b>Mechanical</b>	
Cycle life	> 300,000
Strike Gap	> 7mm
Holding Force	> 10,000N (1000kg)
Side Load Release	> 10,000N (100kg)
Door Misalignment	+/- 8mm
<b>Electrical</b>	
Voltage at Lock	12 - 24 VDC $\pm$ 15%
Current Usage	Holding Current < 40mA@12V < 30mA@24V
	Operating Current < 250mA@12V < 200mA@24V
	Initial Power Up* < 1800mA@12V < 600mA@24V
Monitor Switches	Bolt Position - 30VDC, 0.1A
	Door Position - 100VDC, 0.5A
<b>Certifications</b>	
Patent	Pending PCT/IB2013/053737
FCC	Part 15 Subparts A & B – Unintentional Radiators
CE	EN 61000-6-1: 2007, EMC Directive 2001/108/EC Immunity
	EN 61000-6-3: 2007, EMC Directive 2001/108/EC Emissions

\* Initial power up of the lock requires up to 1800mA@12VDC and up to 600mA@24VDC for up to 6 seconds but only occurs when the power has been completely removed for an extended period then re-applied, for example after a power outage.

**Normal Operating Current after initial power up is <250mA@12VDC and <200mA@24VDC.**



## 9. Maintenance

The SL30SGL has been lubricated at assembly and applying any other type of lubricant may void the warranty. Removing the lock cover may void the warranty. A dry cloth can be used to polish the stainless steel face plate and strike plate as required.

Interval	Activity
As needed:	Using a dry cloth, polish the face plate. Note: Look for traces of dirt and water (dust, escaping lubricant)
Periodically, depending on frequency of use (to be determined by the operator):	Check for: <ul style="list-style-type: none"><li>• Tight fit</li><li>• Smooth running</li><li>• Noise during operation</li><li>• Play of the latch</li><li>• Contamination</li><li>• Escaping lubricant</li><li>• Moisture</li></ul> <p>If there are unusual noises, noticeable play, escaping lubricant or similar; replace the lock.</p>

## 10. Warranty

The SL30SGL is covered with a manufacturer's 12-month warranty against faulty or malfunctioning parts, components or product. At the manufacturer's discretion, either a replacement lock or affected part will be supplied to remedy the fault or the lock can be returned at the customer's expense to the manufacturer for repair. Mistreatment or ill-use of the lock may void the warranty. SL30SGL is a trademark of BQT Solutions (SEA) Pte Limited. BQT Solutions (SEA) Pte Limited will not be liable for any direct, indirect, incidental or consequential loss or damage in any way related to this product.